

Sightglass light fittings

for sterile applications in safe areas, series KLR A / KLR A PowerLED in stainless steel, for mounting onto metal fused sightglasses

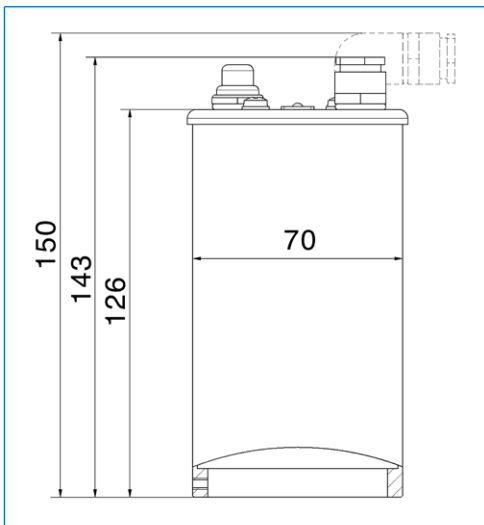

Sightglass light fitting type KLR 20 HDAsp, 20 W, 115 V, with built-in momentary push-button "D", on metal fused sightglass for Triclamp fittings, DN 100



Dimensions

Branch office / exclusive agent:

All dimensions in mm. Subject to changes without preliminary notice.

The sightglass light fittings KLR A / KLR A PowerLED of the series STERI-LINE **entirely in stainless steel** offer the following main features:

- Very interesting prices due to high series production
- Only **one** size for use on different sightglass diameters
- Easy mounting
- **Brilliant and dazzle free illumination**, even of difficult media
- **Extremely small** dimensions providing **high lighting power**
- Suitable for continuous operation
- State-of-the-art LED light source with **life span of up to 40'000 operating hours**
- **UV-free and cold** light output (KLR A PowerLED)

Application:

On metal fused sightglasses and flanges in sterile and aseptic areas, mainly in the pharmaceutical, biotechnological and food processing and cosmetic industries.

Operating conditions:

Independent of internal vessel pressure and vacuum. The series KLR A PowerLED is admitted for ambient temperatures from - 20 °C to + 40 °C.

Construction:

Housing in **stainless steel**. Cable gland Pg 9, vertical. On request with right angle cable gland ("K2"). Built-in reflector (series KLR A) or LED module (series KLR A PowerLED). Built-in push-button for momentary operation "D" (types KLR 05 / 10 / 50 HA / KLR A PowerLED also available **without**, on request).

Technical data:

Type	KLR 05 HDA ¹	KLR 10 HDA ¹	KLR 20 HDA	KLR 50 HDA ¹	KLR 100 HDA	KLR A PowerLED-S D ¹	KLR A PowerLED-F D ¹
Power	5 W	10 W	20 W	50 W	100 W	7 W	
Terminal voltage ²	36 / 42 / 115 / 240 V AC			12 / 24 V AC / DC	24 V AC / DC	24 V AC / DC 230–240 V AC	
Light source	Halogene			Halogene		Diodes "spot"	Diodes "flood"
Socket	G4			GY 6.35		–	
Weight	0,95 kg			0,60 kg		0,65 kg	

¹ For the version **without** push-button, the correct type designation **omits** the "D".

² Transformers with 24 V secondary voltage in open design (IP 00) for mounting into control panels or switch boards as well as in closed version (IP 65) may be supplied for different primary voltages and power capacities.

Enclosure protection degree:

IP 65, dust and spray water tight, to EN 60529 / DIN VDE 0470 part 1.

Mounting:

The light fitting is put onto the adapter ring of the respective sightglass and fixed by means of a hexagonal socket cap screw. The sealing towards the sightglass is guaranteed by an O-ring being part of the adapter piece.

Important remarks:

Please indicate in case of order type and size (DN) of the sightglass on which the luminaire has to be mounted.

In case of repeated use of the series KLR H A within a short period, the temperature raise of the housing has to be observed.