

# Circular sightglasses for welding into or onto vessel walls, in version PN 0 / PN 2,5 with a viewing diameter equal to DIN 28120



Circular sightglass, DN 150, PN 0, with glass disc in sodium silicate to DIN 8902 and wiper of the series W, wiper blade in silicone



Circular sightglass similar to DIN 28120, DN 150, PN 2,5, with glass disc in sodium silicate to DIN 8902

## Application:

The circular sightglass fittings are used for the observation and illumination of the inside of unpressurised vessels, silos, tanks etc. or such of a nominal pressure (PN) of 2,5 bar.

They represent, especially for large nominal diameters, a **cost-saving alternative** to the sightglasses of the pressure rates 6, 10 and 16 bar.

## Viewing diameter:

80–225 mm

## Operating conditions:

Pressure: No pressure (PN 0) resp. PN 2,5  
Temperatures: Max. 150 °C with glass disc in sodium silicate to DIN 8902  
Max. 280 °C with glass disc in borosilicate to DIN 7080

## Materials:

Base flange: 1.4404 (AISI 316 L) (standard)  
1.4541 (AISI 321), RSt 37-2, H II or other materials on demand  
Cover flange: 1.4541 (AISI 321) (standard)  
1.4404 (AISI 316 L), 1.4571 (AISI 316 Ti), RSt 37-2, H II or other materials on demand  
Sightglass disc: Sodium silicate glass to DIN 8902 (standard)  
Borosilicate glass to DIN 7080 on demand  
Gaskets: KLINGERSil C4400, PTFE, Perbunan, Silicon, Viton, Gylon or other materials on demand  
Screws / studs and nuts: A2-70 (standard)  
A4-70 or 5.6 zinked on demand

## Possible combinations:

The sightglasses can be combined with our centrally operated window wipers of the series W / WD / WDT, with the spraying devices of the series SVS (only version for PN 2,5) as well as with our sightglass light fittings of the series CHEMLUX, EdelLUX, miniLUX or fibroLUX for use in hazardous or safe areas. In these cases, the cover flanges are drilled and tapped to suit the respective light fitting fixation.

## Special versions:

- Special high vacuum-tight version with additional O-ring seal
- Glass disc in quartz and special gaskets for very high operating temperatures

## Contents of delivery:

The complete delivery consists of base and cover flanges, glass disc, gaskets for product and cover side and hexagonal socket head screws (version for PN 0) resp. studs and nuts (version for PN 2,5).

## Certificates:

On request against extra charge, to DIN 50049, 3.1(B), alternatively 3.1A for the flanges, 2.2 or 3.1 for the glass discs.

# Dimensions Mounting

## Unpressurised version (PN 0)

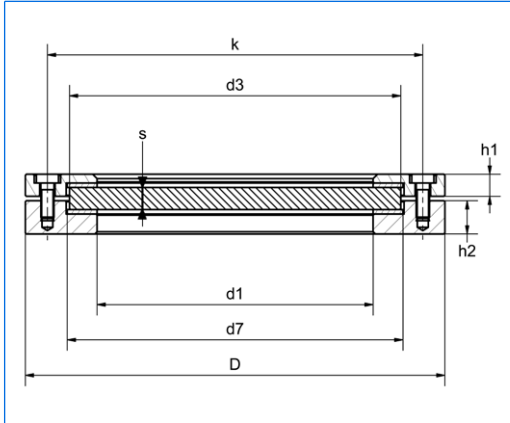

Nominal flange diameter (DN)	d1	d3	s	d7	D	k	h1	h2	Socket head screws
50 *	80	100	10	102	140	120	10	15	4 x M6
80 *	100	125	10	127	165	145	10	15	8 x M6
100 *	125	150	10	152	190	170	10	15	8 x M6
125 *	150	175	10	177	215	195	10	15	8 x M6
150	175	200	10	202	240	220	10	15	8 x M6
200	225	250	10	252	290	270	10	15	8 x M6

\* Not in stock.

## Version for PN 2,5

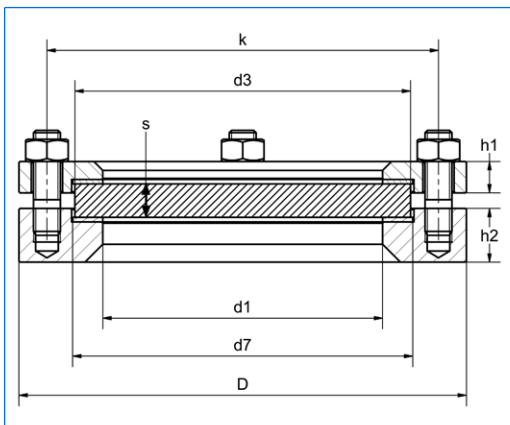

Nominal flange diameter (DN)	d1	d3	s	d7	D	k	h1	h2	Studs
50 *	80	100	10	102	150	125	12	24	4 x M12
80 *	100	125	15	127	175	150	14	24	4 x M12
100 *	125	150	15	152	200	175	14	24	4 x M12
125 *	150	175	15	177	220	195	16	24	8 x M12
150	175	200	15	202	250	220	16	24	8 x M12
200	225	250	15	252	300	275	16	24	8 x M12

\* Not in stock.

### Mounting:

After having correctly welded the base flange onto or into the vessel wall, the product side gasket, the glass disc, the cover side gasket and the cover flange are mounted one after the other and then the socket head screws tightened against the cover flange (version for PN 0) resp. the nuts against the studs (version for PN 2,5).

**Attention:** The base flange has to be welded into or onto the vessel wall without any distortion to ensure a plain and flat sealing surface to avoid the breakage of the glass disc. If necessary, rework the sealing surface after welding. The screws have to be tightened evenly and crosswise.

Branch office / exclusive agent:

Do you wish for more information about our wide range of light fittings for use in hazardous and safe areas, camera systems for hazardous areas, about our range of circular sightglasses to DIN 28120/28121, screwed sightglasses similar to DIN 11851, rectangular or D-ended sightglasses, sightglasses and light fittings for sterile applications STERI-LINE, pipeline flow indicators, centrally or sideways operated wipers, hinged sightglasses, spraying devices or our complete sight and lightglass units VETROLUX? Are you interested in other types, special versions or different protection degrees? If yes, please contact us, our branch office or our local agents – it is our business! You will find the necessary indications about our sales network on the Internet.