

Circular sightglass fittings to DIN 28120 or similar

Circular sightglass fittings to DIN 28121 Illuminated sightglass units VETROLUX



Complete assembly of sightglass fitting to DIN 28120, DN 100, PN 10, with glass disc of borosilicate to DIN 7080.



Complete assembly of sightglass fitting to DIN 28120, DN 125, PN 10, with glass disc of toughened sodium silicate to DIN 8902, fitted with CHEMLUX sightglass light fitting, type L 20 deH Sch, tilting hinge fixation

In addition to the well known programme of sightglass light fittings, MAX MÜLLER AG supplies complete sightglass fittings to or similar to DIN 28120 and to DIN 28121. These form, together with the reliable light fittings of the series CHEMLUX, EdelLUX, fibroLUX, miniLUX or metaLUX, complete illuminated sightglass units VETROLUX where both components are thoroughly determined and correctly chosen. The units are supplied as premounted sets, offering the following advantages:

- **Only one supplier**
- **Responsibility from one hand**
- **Components mutually adapted, avoiding therefore mounting problems or eventual expensive adjustments.**

With MAX MÜLLER AG, you have chosen the right and efficient partner, offering excellent service and high quality to very interesting prices. Ask the experts of MAX MÜLLER AG for advice and integrate VETROLUX units into your installations. Remember: Our product range has a background of more than 40 year's experience and development. Both you and your customers will benefit from this know-how.

Application:

In all cases where chemical or physical processes, reactions or e.g. fluid levels have to be observed, controlled or read off at the interior of stirred tanks, dryers, columns, silos, centrifuges, mixers, reactors, evaporators, separators, pipelines, pressure vessels or other closed containers.

Nominal diameters:

PN 10, 16: DN 50 - 200 (DIN 28120)
PN 6: DN 50 - 200 (similar to DIN 28120)
PN 10, 25: DN 40 - 200 (DIN 28121)

Operating conditions:

Max. pressure: DIN 28120: 10, 16, (6) bar
DIN 28121: 10, 25 bar
Higher pressures on demand

Vacuum

Possible combinations:

Sightglass fittings to DIN 28120 or to DIN 28121 **may be combined with our sightglass light fittings of the series CHEMLUX, EdelLUX, fibroLUX, miniLUX or metaLUX for use in hazardous or in safe areas.** The cover flanges are drilled and tapped to be fitted with the respective light fitting in case of ordering the complete VETROLUX unit.

Sightglass fittings to DIN 28120 or similar **may further be equipped with window wipers of the series W, WD or WS (attention to the pressure limits!) as well as with spraying devices of the series SV / SVS** for the occasional or continuous cleaning of the sightglass disc. (See separate leaflets).

Certificates:

To be supplied against extra charge to DIN EN 10204.

Circular sightglass fittings to DIN 28120 (PN 10, 16) Circular sightglass fittings similar to DIN 28120 (PN6)

Dimensions

Assembly and construction materials

Mounting

Our circular sightglass fittings to be welded into or onto vessel walls correspond in their construction and assembly to the dimensions and constructional guidelines of the DIN specification 28120. The respect of the DIN prescriptions for the flange thicknesses guarantees a distortion free location of the sightglass disc. The pressure resistance of the sightglass disc is, of course, dependent on the care with which the bolts and nuts are tightened (always working on diametrically opposed pairs). For lubricated bolts, $\mu = 0.1$, the recommended tightening torque values (in Nm) are indicated in the table below. The maximum operating temperature is limited to 150 °C when using sightglass discs of sodium silicate to DIN 8902 and to 280 °C when using sightglass discs of borosilicate to DIN 7080. This temperature is also function of the quality of the used gaskets. For operating temperatures lower than -10 °C, please consult the descriptive sheet AD 2000 W 10.

Nominal diameter (DN)	Nominal pressure (PN) (bar)	Viewing diameter d_1	Glass disc		Base flange and cover flange				Bolts or studs and nuts		
			d_4	s	D	k	h_1	h_2	Number	Size	Tightening torque (Nm)
50	6	80	100	10	165	125	16	30	4	M 16	
	15			28							
	15			32							
80	6	100	125	15	200	160	20	30	8	M 16	
	15			20							
	20			23							
100	6	125	150	15	220	180	18	30	8	M 16	
	20			22			26				
	25			22			30				
125	6	150	175	20	250	210	18	30	8	M 16	
	20			25			32				
	25			25			34				
150	6	175	200	20	285	240	18	36	8	M 20	
	25			30			47				
	30			30			54				
200	6	225	250	25	340	295	20	36	8	M 20	
	10			35			63				

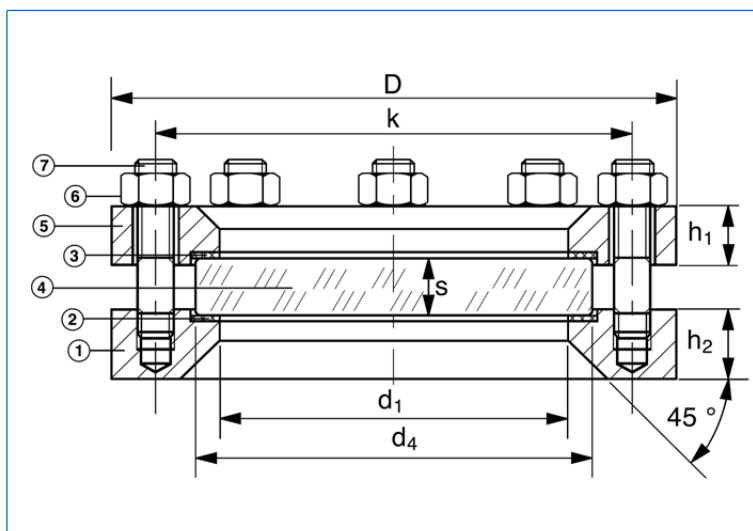

A special high vacuum-tight version with additional O-ring seal in different materials may be delivered on demand.

Assembly and construction materials:

		Standard	On demand*
①	Base flange	Steel RSt 37-2	1.4404
⑤	Cover flange	1.4571 (= AISI 316 Ti) or 1.4541 (= AISI 321)	(= AISI 316 L) Aluminium Titan Inconel Steel zinked
②	Gaskets	KLINGERSil C 4400	PTFE Silicone Viton Gylon
④	Glass disc	Sodium silicate to DIN 8902 (max. 150 °C)	Borosilicate to DIN 7080 (max. 280 °C) Quartz
⑥	Nuts		
⑦	Bolts or studs	5.6 / 5.2	A2 / A4

* Other materials not mentioned in the above table may also be delivered.

Mounting:

After having correctly welded the base flange ① onto or into the vessel wall, the gasket ②, the glass disc ④, the gasket ③ and the cover flange ⑤ are mounted one after the other and then the nuts ⑥ (in case of studded base flange ①) progressively crosswise tightened against the studs ⑦. The above indicated tightening torque values have to be strictly respected. Additional information may be taken from the DIN specification 28120.

Circular sightglass fittings to DIN 28121 (PN 10, 25)

Dimensions Assembly and construction materials Mounting

Our circular sightglass fittings to be mounted directly onto a welding flange, pad or similar correspond in their construction and assembly to the dimensions and constructional guidelines of the DIN specification 28121. The sightglass fittings are completely premounted at manufacturer's works to form an integral, sealed, finished unit. The maximum operating temperature is limited to 200 °C. For higher operating temperatures, versions similar to DIN 28121 can be delivered on request, these with other seal and/or glass qualities.

The units may be used until -1 bar. For operating temperatures lower than -10 °C, please consult the descriptive sheet AD 2000 W 10.

Nominal diameter (DN)	Nominal pressure (PN) (bar)	Viewing diameter		Glass disc		Flanges			Fixation bolts		Gaskets	
		d ₁	d ₂	d ₃	s	D	k	h ₃	Number	Size	d ₁	d ₁₀
40	10	48	43	63	10	150	110	36	4	M 16	48	65
	25				12	150	110	38	4	M 16		
50	10	65	60	80	12	165	125	38	4	M 16	65	82
	25				15	165	125	41	4	M 16		
80	10	80	75	100	15	200	160	46	8	M 16	80	102
	25				20	200	160	50	8	M 16		
100	10	100	95	125	15	220	180	46	8	M 16	100	127
	25				25	235	190	59	8	M 20		
125	10	125	120	150	20	250	210	54	8	M 16	125	152
	25				30	270	220	66	8	M 24		
150	10	125	120	150	20	285	240	54	8	M 20	125	152
	25				30	300	250	66	8	M 24		
200	10	150	145	175	20	340	295	54	8	M 20	150	177
	25				30	360	310	66	12	M 24		

Version A Without protective coating of sealing face

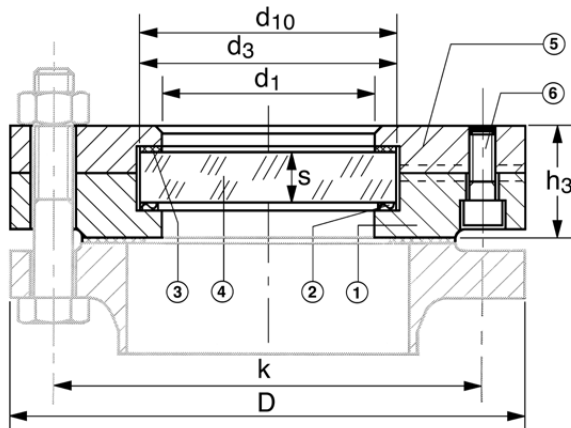

The design shows the sealing face of form B1

Version B With protective coating of sealing face

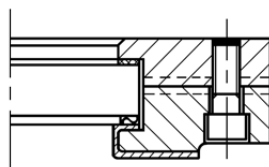

Assembly and construction materials:

①	Base flange (Version A) Form B1: Raised faced to DIN EN 1092-1 (standard) Form C: Tongue to DIN EN 1092-1 Form E: Male socket to DIN EN 1092-1 Base flange (Version B) (only deliverable with sealing face of form B and E)	Boilerplate H II to DIN 17155 Stainless steel 1.4571 (= AISI 316 Ti) to DIN 17440 Other materials on demand Boilerplate H II with coated sealing surface. (The maximum admitted temperature of the coating has to be respected)
②	Gasket product side	PTFE-covered ring gasket with internal support ring
③	Gasket cover side	KLINGERSil C 4400
④	Glass disc	Borosilicate to DIN 7080 (max. 280 °C)
⑤	Cover flange	Boilerplate H II to DIN 17155 Stainless steel 1.4541 (= AISI 321) Stainless steel 1.4571 (= AISI 316 L) Other materials on demand
⑥	Security tightening bolts	A2 or A4 or 8.8

Mounting:

By using the fixation bolts of which the number and size are indicated in the above table, the complete, premounted, tightened and sealed unit is fixed onto a welding flange, pad or similar.

Possible standard combinations of the CHEMLUX, EdelLUX, fibroLUX, miniLUX and metaLUX light fittings with sightglass units to DIN 28120 / 28121



VETROLUX illuminated sightglass unit, consisting of sightglass to DIN 28120, DN 150, PN 10, with mounted CHEMLUX light fitting, type KEL 20 deH Sch B, 230 V, 20 W, Ex d e IIC T4 Gb, Ex t IIIC T130°C Db IP67, Ex II 2 G + D, with anti-dazzle shield "B", in version "view **and** light through **one** assembly"



VETROLUX illuminated sightglass unit, consisting of sightglass to DIN 28120, DN 80, PN 10, with mounted CHEMLUX light fitting, type F 20dHNsp, 24 V, 20 W, Ex d IIC T5 Gb, Ex t IIIC T95°C Db IP 67, Ex II 2 G + D

The table below indicates the possible standard combinations of our light fitting series with the respective nominal diameters of sightglasses to DIN 28120 / 28121:

Nominal diameter (DN)		40		50		80		100		125		150		200	
Sightglass to DIN 28120 (A)		A	B	A	B	A	B	A	B	A	B	A	B	A	B
Sightglass to DIN 28121 (B)		A	B	A	B	A	B	A	B	A	B	A	B	A	B
Series / Type	Fixation														
F 20 dH / L 20 deH / R 50 deH / R 100 deH	... N			•	•	•	•	•	•						
	... Z							•	•	•	•				
	... Sch							•	•	•	•	•	•		
100 deH	... N					•	•	•	•	•	•	•	•	•	•
	... Z											•	•		
	... Sch									•	•	•	•		
KVLR / BKVLR	... W/Sch	•	•	•	•	•	•	•	•	•	•	•	•	•	•
KLR	... Sch	•	•	•	•	•	•	•	•	•	•	•	•	•	•
MVLR	... Sch	•	•	•	•	•	•	•	•	•	•	•	•	•	•
HL 50 H				•											
HL 80 H					•										
HL 100 H								•							
HL 125 H									•						•
HL 150 H										•					
HL 200 H														•	
(F)HEL / FHL	... W					•	•	•	•	•	•	•	•	•	•
	... Sch	•	•	•	•	•	•	•	•	•	•	•	•	•	•
F(L)KEL / (L)KEL / KL	... W					•	•	•	•	•	•	•	•	•	•
	... Sch	•	•	•	•	•	•	•	•	•	•	•	•	•	•
PEL / PL	... Sch									•	•	•	•	•	•
	... X1			•	•	•	•	•	•	•	•	•	•		•
	... X2									•	•	•			
EdelEx 5 dH / 10 dH / 20 dH / PowerLED	... Sch	•	•	•	•	•	•	•	•	•	•	•	•	•	•
EdelEx G 20 dH / 50 dH	... Sch					•	•	•	•	•	•	•	•	•	•
fibroLUX	... W2	•	•	•	•	•	•	•	•	•	•	•	•	•	•
	... W3	•	•	•	•	•	•	•	•	•	•	•	•	•	•

Branch office / exclusive agent:

Do you wish for more information about our wide range of light fittings for use in hazardous or safe areas, camera systems for hazardous areas, about our range of circular sightglasses to DIN 28120/28121, screwed sightglasses similar to DIN 11851, rectangular or D-ended sightglasses, pipeline flow indicators, sideways or centrally operated wipers, hinged sightglasses, spraying devices or our complete sight and light-glass units VETROLUX? Are you interested in other types, special versions or different protection degrees? If yes, please contact us, our branch office or our local agents – it is our business! You will find the necessary indications about our sales network on the Internet.