

Flow indicators for pipelines with ends for welding

Series S-VA in stainless steel

Series S-St in carbon steel



Sight flow indicator, series S-VA, type S-VA 80

Application:

VETROLUX® sight flow indicators, series S-VA / S-St with the new DIN lengths, are used for the observation of a flow of liquid in tubes and pipelines. Visibility may be considerably enhanced by combination with our proven light fittings for hazardous and safe areas. (Please see our respective leaflets.)

Operating conditions:

Nominal pressure: 10 bar (PN 10)
16 bar (PN 16) on request

Vacuum

Maximum temperature: 280 °C (with borosilicate glass discs)
150 °C (with sodium silicate glass discs)

Standard materials:

Body material:	Series S-VA:	1.4571 (= AISI 316 Ti)
	Series S-St:	Carbon steel RSt 37-2
Cover flanges:	Series S-VA:	Stainless steel
	Series S-St:	Carbon steel RSt 37-2
Socket head screws:	Series S-VA:	A4-70
	Series S-St:	Zinked 5.6
Glass discs:		Borosilicate glass to DIN 7080 (Standard)
		Sodium silicate glass to DIN 8902 (Option)
Gaskets product side:		Graphite
cover side:		KLINGERSil C4400

Other materials are available on request.

Options:

- Security version with double glazing

Remarks:

When enquiring or ordering please **always** state the nominal pressure (PN) required.

Ordering example:

1 piece VETROLUX® sight flow indicator for welding into position, body in stainless steel 1.4571 (= AISI 316 Ti), nominal pressure 10 bar (PN 10), nominal diameter DN 25:

1 piece S-VA 25-316 Ti-10-Graphite-KLINGERSil C4400

Type selection table

Dimensions

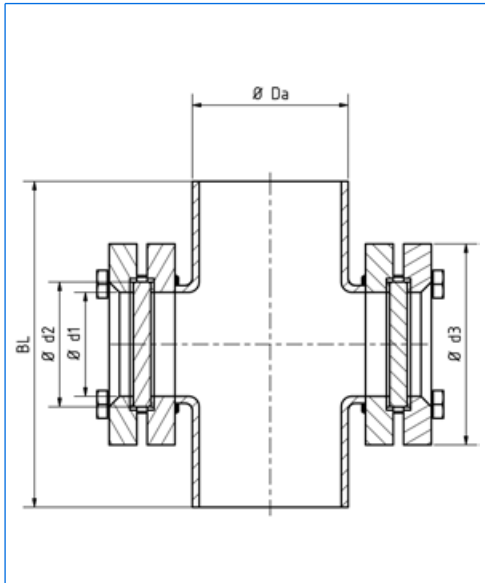

Typ	DN	BL	Ø Da	Ø d ₃	Ø d ₁	Number and size of bolts	Ø d ₂	s
S-VA 25	25	160	33,7	□ 70	23	4 x M10	45	10
S-St 25								
S-VA 40	40	200	48,3	□ 85	39	4 x M12	63	10
S-St 40								
S-VA 50	50	230	60,3	□ 85	44	4 x M12	63	10
S-St 50								
S-VA 80	80	310	88,9	135	64	4 x M12	80	12
S-St 80								
S-VA 100	100	350	114,3	150	80	4 x M12	100	15
S-St 100								
S-VA 125	125	400	139,7	150	80	4 x M12	100	15
S-St 125								
S-VA 150	150	480	168,3	190	100	4 x M16	125	20
S-St 150								
S-VA 200	200	600	219,1	210	125	8 x M16	150	25
S-St 200								
S-VA 250	250	730	273,0	235	150	8 x M16	175	25
S-St 250								
S-VA 300	300	850	323,3	235	150	8 x M16	175	25
S-St 300								

Branch office / exclusive agent:

Do you wish for more information about our wide range of light fittings for use in hazardous or safe areas, about our range of circular sightglasses to DIN 28120/28121, screwed sightglasses similar to DIN 11851, rectangular or D-ended sightglasses, pipeline flow indicators, sideways or centrally operated wipers, hinged sightglasses, spraying devices, camera systems for hazardous areas or our complete sight and light-glass units VETROLUX®? Are you interested in other types, special versions or different protection degrees? If yes, please contact us, our branch office or our local agents – it is our business! You will find the necessary indications about our sales network on the Internet.