

Metal fused sightglasses for Triclamp fittings

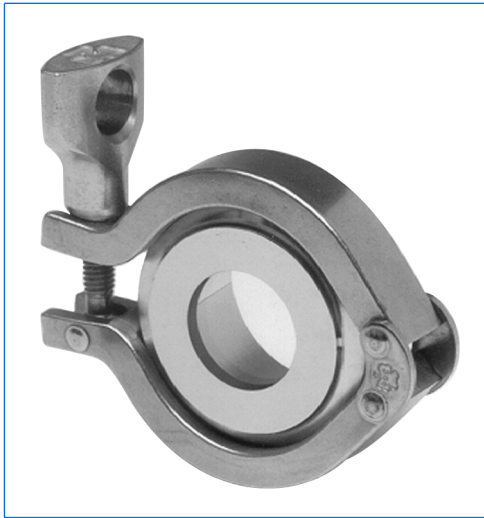

Metal fused Triclamp sanitary sightglass fitting, type "Standard View" (SV)



Metal fused Triclamp sanitary sightglass fitting, type "Large View" (LV)

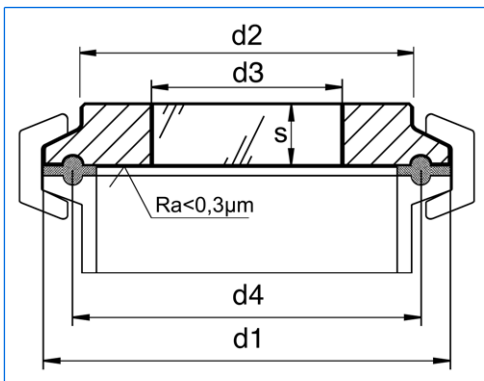

Typical assembly

All dimensions in mm. Subject to changes without preliminary notice.

Applications:

For clamp fittings to DIN 32676 / ISO 2852

Versions:

- Version with standard view, type "Standard View" (SV)
- Version **with enlarged view**, type "Large View" (LV)

Advantages:

- Suitable for food processing and sterile applications
- High security
- Easy installation

Technical data:

- Test base: DGRL 97 / 23 / EG, AD 2000 standards, DIN 7079-1 May 1999
- Materials to VdTÜV specifications and the respective DIN/EN standards

Certificates:

To be supplied to DIN EN 10204-3.1 against extra charge

Operating conditions:

- Pressure: -1 to 6 / 10 / 16 / 25 bar (see table)
- Temperatures:

Ring materials:	1.4462:	- 30 °C to + 280 °C (SV) / +150 °C (LV)
	2.4602:	- 60 °C to + 300 °C (SV) / +150 °C (LV)
	2.4610:	- 60 °C to + 300 °C (type SV only)

Materials:

- Ring: 1.4462, 2.4602, 2.4610 (SV) / 1.4462, 2.4602 (LV)
- Glass quality: Borosilicate to DIN 7080 (SV)
Sodium silicate to DIN 8901 (quality B270 Superwite) (LV)

Dimensions:

Nominal diameter			d1	d2		d3		d4	S		Max. operating pressure (bar)
DN to DIN	DN to ISO	ASME-BPE Inch		SV	LV	SV	LV		SV	LV	
-	-	1/2"/3/4"	25	18	-	10	-	20,5	10	-	25
10/15/20	8/10/15	-	34	21	-	14	-	27,5	8	-	25
25/32/40	20/25/32	1 1/16"	50,5	41	42,5	25	30	43,5	10	10	16
50	40	2"	64	52	55,6	30	37	56,5	10	12	16
-	50	2 1/2"	77,5	67	67	35	45	70,5	10	14	16
65	65	3"	91	76	82,4	40	55	83,5	10	14	10
80	80	3 1/2"	106	90	90	50	60	97	10	15	10
100	-	4"	119	101	108	55	75	110	12	18	10
-	100	4 1/2"	130	114	-	60	-	122	16	-	10
-	-	5"	144,5	127	-	65	-	134,5	16	-	10
125	-	-	155	138	-	70	-	146	16	-	6
-	-	6"	167	152	152	75	105	156,5	16	22	6
150	-	-	183	160	-	80	-	174,3	16	-	6
-	-	8"	217,5	198	203	100	130	207,4	18	24	6
200	-	-	233,5	210	-	100	-	225,1	18	-	6
-	-	10"	268	245	245	120	160	257,8	20	25	6
250	-	-	287,5	266	-	140	-	278,4	22	-	6
-	-	12"	319,3	300	300	140	200	309,1	22	30	6
300	-	-	338,3	316	-	150	-	328,4	22	-	6