

Metal fused sightglasses for NA-Connect™-connections



NA-Connect™ sightglass

Application:

For NA-Connect™-connections

Advantages:

- Extremely compact construction
- High security
- Easy installation
- For sterile applications
- CIP cleaning possible

Technical data:

- Test base: DGRL 97 / 23 / EG, AD 2000 standards, DIN 7079-1 May 1999
- Materials to VdTÜV specifications and the respective DIN/EN standards
- Glass quality: Borosilicate glass to DIN 7080

Certificates:

- To be supplied against extra charge to DIN EN 10204

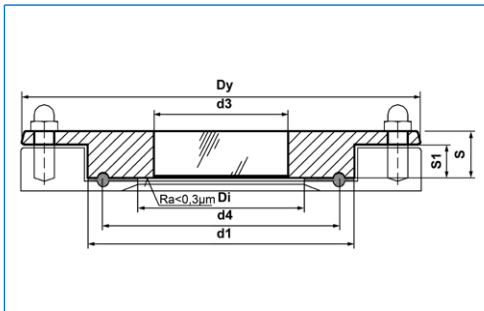

Typical assembly

Operating conditions:

- Temperatures:

Ring materials:	1.4462:	-30 °C to +280 °C
	2.4602:	-60 °C to +300 °C
	2.4610:	-60 °C to +300 °C

NA-Connect™:

Materials welding flange: 316 L / 1.4435
 Nominal pressure: 7 bar (PN 7)
 Nominal temperature: 150 °C

Dimensions:

Nominal diameter		NA-Connect-welding flange		d1	d3	d4	S1	S	Dy	Di
(inch)	(mm)	DIN	Tube OD							
½" / ¾"	-	-	NAC-OD-¾"	25,0	13	20,2	6	11	55	15,0
-	10 / 15 / 20	NAC-DIN-20	-	34,0	18	27,5	6	11	70	20,0
1" / 1½"	25 / 32 / 40	NAC-DIN-40	NAC-OD-1½"	50,5	30	43,5	7	13	85	35,5
2"	50	NAC-DIN-50	NAC-OD-2"	64,0	35	56,5	8	14	100	48,5
2½"	-	-	NAC-OD-2½"	77,5	40	69,0	8	17	112	60,2
3"	65	NAC-DIN-65	NAC-OD-3"	91,0	45	83,5	8	18	131	72,0
3½"	80	NAC-DIN-80		106,0	60	97,0	8	18	146	84,9
4"	100	NAC-DIN-100	NAC-OD-4"	119,0	65	110	8	18	170	97,6

Branch office / exclusive agent: