

SIGHTGLASS LIGHT FITTINGS

Series HL / HLM / HLMR for view and light through one assembly for application in safe areas.

- Only one assembly necessary
- Very interesting prices
- Easiest mounting
- Brilliant illumination of all kind of vessels and apparatuses
- To be delivered also as complete units VETROLUX with sightglasses

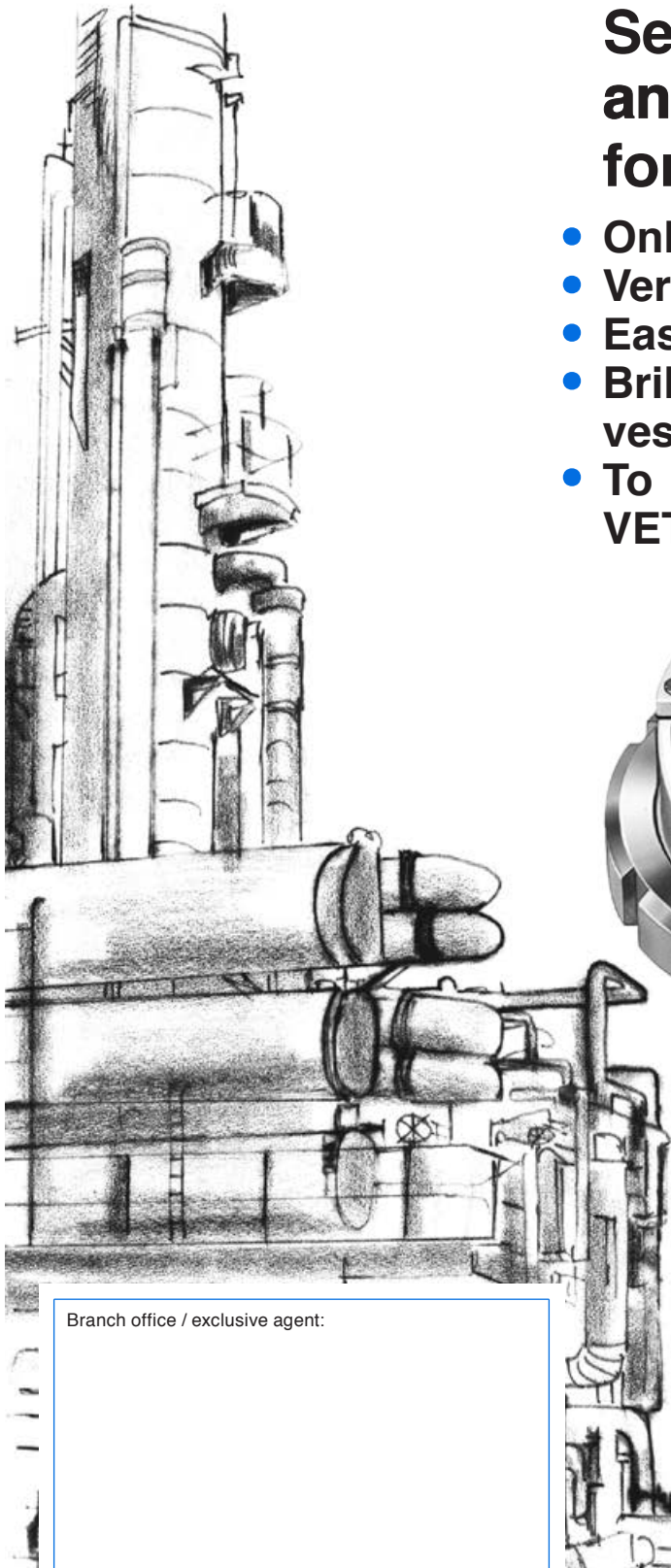

Left:
Sightglass light fitting type HLM 80 H, mounted on screwed sightglass similar to DIN 11851, series SSA, DN 80, PN 6.



Below:
Sightglass light fitting type HL 80 H, combined with wiper of the series W, mounted on sightglass to DIN 28120, DN 80, PN 6.

Branch office / exclusive agent:

Introduction and short information

General technical data

Description and mounting for series HL on sightglasses to DIN 28120

In the chemical and pharmaceutical industries, in breweries, salt works, in water treatment plants, in the food and drink industries, in the dairy industry, sugar factories, dye and paint manufacturing plants, in the soap and cosmetics industry, the problem often arises how to light out agitated vessels, holding vessels, reactors, crystallizers, distillation columns, evaporators, centrifuges, upright vessels, silos, driers and similar equipment.

The reason for this is that, regardless of automation, manufacturing processes must be checked visually, liquid levels read off and drying or fermentation processes kept under observation. In other words, it is essential to carry out visual observation, either on a routine basis or, when necessary, daily or from hour to hour. And whenever an observation or a reading must be carried out, one needs – light! This is what we provide

with our range of light fittings for sightglass application, bundled, efficient, reliable, effective even when the sightglass is caked or the substances inside the vessels are highly light absorbent.

If required, our light fittings may be used round the clock or temporarily, depending on the equipment of the light fitting chosen. If you have a lighting problem – ask the experts for advice and use for your installations products of MAX MÜLLER AG. They have been thoroughly tested, are being used throughout the world, and are both solid and safe.

Remember: Our product range has a background of 40 years' experience, research and development in sight-glass light fitting technology. Both you and your customers will benefit from this technical know-how.

Application: On sightglasses to DIN 28120 or similar of DN 50–200, for “view and light through one assembly”. Admitted for use in food processing industries.

Operating conditions: metaLUX sightglass light fittings of the series HL are mounted independently of pressure or vacuum of the apparatus to be fitted on. There are no restrictions for the mounting position. With built-in push-button for momentary illumination or built-in “ON-OFF” switch (“E”) or in the version with electronic operation limitation (timer), the temperature in the connection box should not exceed 70 °C.

Electrical data:

Supply:	AC or DC
Terminal voltage:	24 V (12 V possible for several types, see page 4)
Maximum current:	4,2 A
Rating:	20 / 50 / 100 W, depending on the type (see page 4)
Bulbs:	Halogen, for sockets G4 or GY 6.35

Enclosure protection degree: When correctly mounted IP 65, dust and spray water tight, to EN 60529 / DIN VDE 0470 part 1.

Construction and description: Housing (1) and cover (2) of corrosion resistant cast aluminium alloy, polished (on request covered by 2 components acryl based colour). Cable gland Pg 9 (3). Connection to terminals 2.5 mm². Reflector incorporated. Built-in push-button (4) for momentary illumination (on request also available without for continuous operation or with “ON-OFF”-switch “E”). Gaskets resistant against corrosion and alteration.

Types HL 80 H up to HL 200 H may be combined with wipers of the series W / WD.

Mounting: The exploded picture right shows the mounting of a metaLUX light fitting on a circular sightglass. The light fitting is fixed on the upper flange by 2 or 4 bolts (see page 4).

The sealing between the glass disc of the sightglass and the housing (1) of the light fitting is assured by the gasket with bridge (5) in Garlock Blue Gard 3000 (or similar), glued to the housing (1). The fixation bolts and spring washers (6), in 8.8 zinked, are contained in our delivery.

Change of bulbs: By lifting the cover (2) and demounting the bulb socket. Therefore **no** interruption of the process.

Transformers in different versions may be supplied on request. The sightglass light fittings metaLUX may be delivered also as complete lighting units VETROLUX for combined light and view with sightglasses (to or similar to DIN 28120 / 28121).

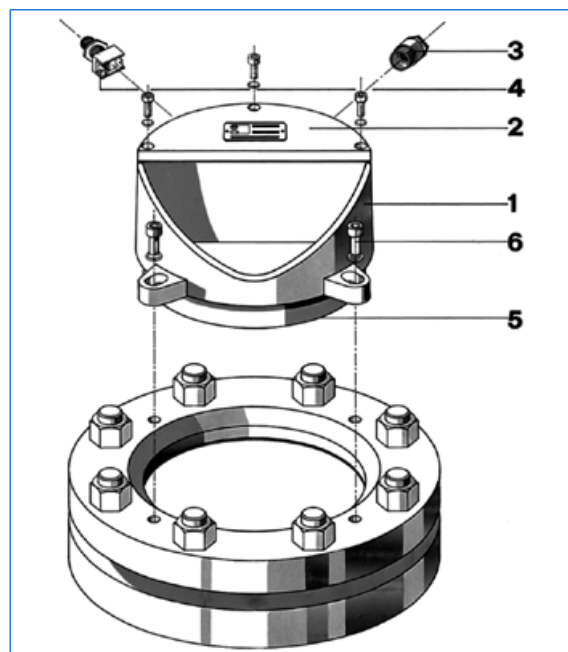

Short information

General technical data

Description and mounting for series HLM/HLMR on sight-glasses similar to DIN 11851

- Application:** On screwed sightglasses similar to DIN 11851 of DN 65–125, for “view **and** light through **one** assembly”. Preferably used in pharmaceutical, cosmetic and food processing industries (dairy industries, breweries, etc).
- Operating conditions:** metaLUX sightglass light fittings of the series HLM / HLMR are mounted independently of pressure or vacuum of the apparatus to be fitted on. There are no restrictions for the mounting position. With built-in push-button for momentary illumination or built-in “ON-OFF” switch (“E”), the temperature in the connection box should not exceed 70 °C.
- Electrical data:**
- | | |
|-------------------|---|
| Supply: | AC or DC |
| Terminal voltage: | 24 V (12 V possible for several types, see page 4) |
| Maximum current: | 4,2 A |
| Rating: | 20 / 50 / 100 W, depending on the type (see page 4) |
| Bulbs: | Halogen, for sockets G4 or GY 6.35 |
- Enclosure protection degree:** When correctly mounted IP 65, dust and spray water tight, to EN 60529 / DIN VDE 0470 part 1.
- Construction and description:** Housing (1) and cover (2) of corrosion resistant cast aluminium alloy, painted RAL 9001 (series HLM) or stainless steel 1.4301 (= AISI 304), polished (series HLMR). Cable gland Pg 9 (3). Connection to terminals 2.5 mm². Built-in reflector and push-button (4) for momentary illumination (on request also available without for continuous operation or with “ON-OFF” switch “E”). Gaskets resistant against corrosion and alteration.
- **Series HLMR made entirely of stainless steel AISI 304**
 - **Types HLM 65 H (DN 65) up to HLM 125 H (DN 125) and HLMR 65 H (DN 65) up to HLMR 125 H (DN 125) may be combined with wipers of the series W / WD!**

- Materials of the screwed sightglass SSA:**
- | | |
|-------------------------|--|
| Grooved collar | 1.4307 (= AISI 304 L) or nut (6): 1.4301 (= AISI 304) |
| Gasket with bridge (5): | Garlock (HLM) / Nitrile (HLMR, max. operating temperature 100 °C), admitted for use in food processing industries |
| Glass disc (7): | Sodium silicate glass to DIN 8902 (max. operating temperature 150 °C) or borosilicate glass to DIN 7080 (max. operating temperature 280 °C) |
| Gasket (8): | Silicone, EPDM, Viton, PTFE, Perbunan |
| Welding nozzle (9): | 1.4404 (= AISI 316 L) or 1.4307 (= AISI 304 L). Other materials on request. Certificates to DIN EN 10204 may be supplied against extra charge. |

Mounting: The exploded picture right shows the mounting of a metaLUX light fitting on a screwed sightglass. The gasket (5) is glued to the housing of the light fitting (1). After welding of the nozzle (9) to the wall of the apparatus, the gasket (8), the glass disc (7) and the light fitting (1) are positioned as shown and fixed by screwing the grooved collar nut (6) onto the welding nozzle (9).

Change of bulbs: By lifting the cover (2) and demounting the bulb socket under full operation of the vessel. Therefore **no** interruption of the process.

Transformers: May be supplied on request in different versions.

Typical assembly (standard delivery) of a screwed illuminated light-sightglass of the series HLM(R)-SSA. (The light fitting may also be delivered as separate unit).

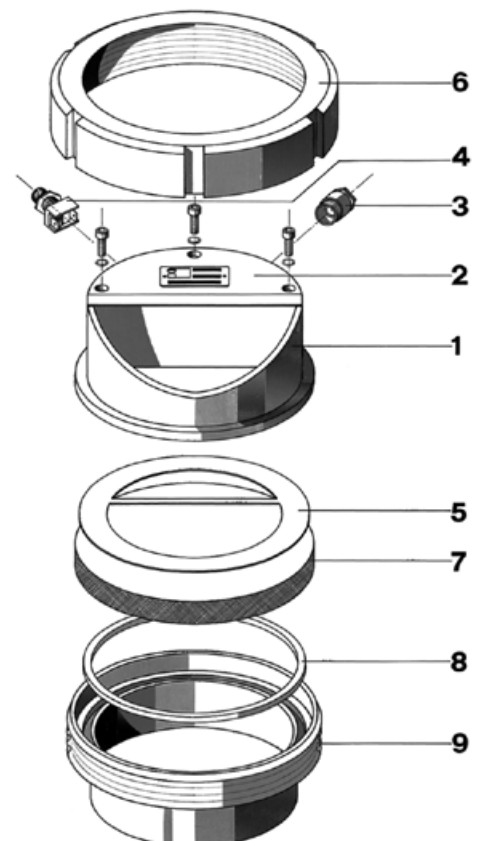

Dimensions

Electrical data

Series HL

HLM

HLMR

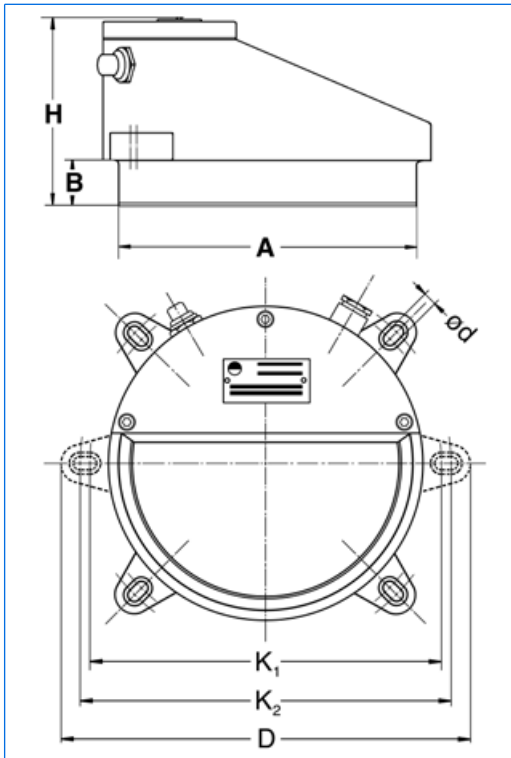

Type		HL 50 H	HL 80 H	HL 100 H	HL 125 H	HL 150 H	HL 200 H
Adapted to sightglass to DIN 28210	DN	50	80	100	125	150	200
Supply voltage	V	24 (12)	24 (12)	24 (12)	24 (12)	24 (12)	24 (12)
Rating *only with 24 V	W	20	20 (50)	50 (100)*	50 (100)*	100* (50)	100* (50)
Pitch circle \varnothing	K ₁	106	128	157	182	210	270
	K ₂	116	138	167	192	220	280
Dimensions	D	134	158	187	212	245	306
	A	79	99	124	148	173	224
	B	16	18	20	23	28	33
	H	67	74	85	93	107	107
Fixation holes	d	2 x 7	2 x 7	4 x 7	4 x 7	4 x 9	4 x 9
Screws		M6 x 16	M6 x 16	M6 x 16	M6 x 20	M8 x 20	M8 x 20
Weight ca.	kg	0.40	0.50	0.80	1.10	1.60	2.00

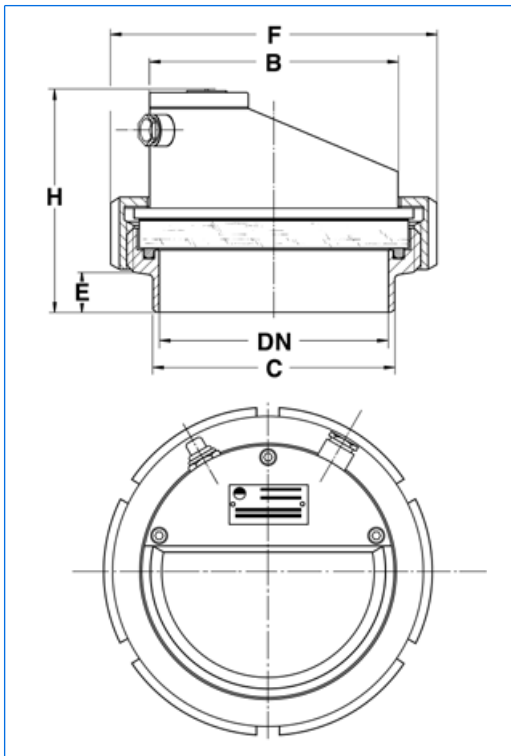

Type		HLM 65 H HLMR 65 H	HLM 80 H HLMR 80 H	HLM 100 H HLMR 100 H	HLM 125 H HLMR 125 H
Adapted to sightglass similar to DIN 11851	DN	65 (SSA 65)	80 (SSA 80)	100 (SSA 100)	125 (SSA 125)
Supply voltage	V	24 (12)	24 (12)	24 (12)	24 (12)
Rating *only with HLM in 24 V	W	20	20	20 (50)	50 (100)*
Dimensions	F	112	127	148	178
	C	72	87	106	132
	B	79	92	113	136
	H	107 99	107 111	119 129	124 120
	E	24	25	34	22

Do you wish for more information about our wide range of light fittings for use in hazardous and safe areas, camera systems for hazardous areas, about our range of circular sightglasses to DIN 28120/28121, screwed sightglasses similar to DIN 11851, rectangular or D-ended sightglasses, pipeline flow indicators, centrally or sideways operated wipers, hinged sightglasses, spraying devices or our complete sight and lightglass units VETROLUX? Are you interested in other types, special versions or different protection degrees? If yes, please contact us, our branch office or our local agents – it is our business! You will find the necessary indications about our sales network on the Internet.